



Clausing 10" (254mm) Wet Cutting Bandsaw

Features:

- 2 Hp (1.5kw) drive motor with magnetic starter and overload protection
- Quick positioning 45° vise
- Cast iron bed
- Totally enclosed transmission
- Quick and simple speed change
- 1" (254mm) wide blade
- Blade cleaning brush
- Solid carbide blade guides with rollers
- Recirculating coolant system with application through both guides
- Stock stop
- Easily adjusted head feed
- Head control is hydraulic cylinder operated by needle valve
- Two (2) year limited warranty

Specifications

Model	HBS-1018
Type	Horizontal wet cut
Drive Motor	2 Hp. (1.5kw) 110v or 220v 1 Ph 230v or 460v 3 Ph
Blade Wheel Dia.	15.4" (391mm) flanged, cast iron
Blade	1" x .035" x 11'-4.5" (25 x .9 x 3645mm)
Bed Height	22" (559mm)
Blade Speeds	(4) 80, 200, 300, 430 fpm (24, 61, 91, 131 mpm)
90° Cutting Capacity	
Round	10" (254mm)
Rectangular	18" x 6" or 10" x 16" (457x152 or 254x 406mm)
45° Cutting Capacity	
Round	8" (203mm)
Rectangular	7"x 10" (179 x 254mm)
Width	80.25" (2038mm)
Depth	33.13" (842mm)
Height (head-up)	45.25" (1150mm)
Height (head-down)	45.25" (1150mm)
Net Weight	704 lbs (319kg)
Shipping Weight	900 lbs (408kg)

Accessories

P10	Stock Stand Assembly 21" - 30"
RT0516	Roller Table Assembly 5' x 16"
RT1016	Roller Table Assembly 10' x 16"
BT01	Bandsaw Blade Tension Gauge

Cutting Capacities:

Capacity at 90°

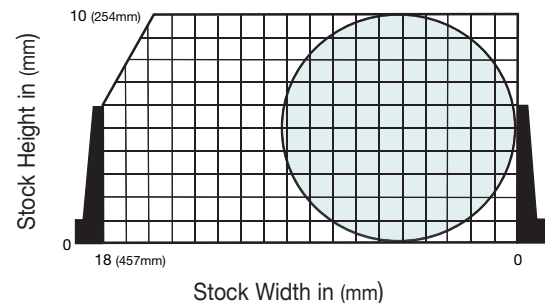

Capacity at 45°

